

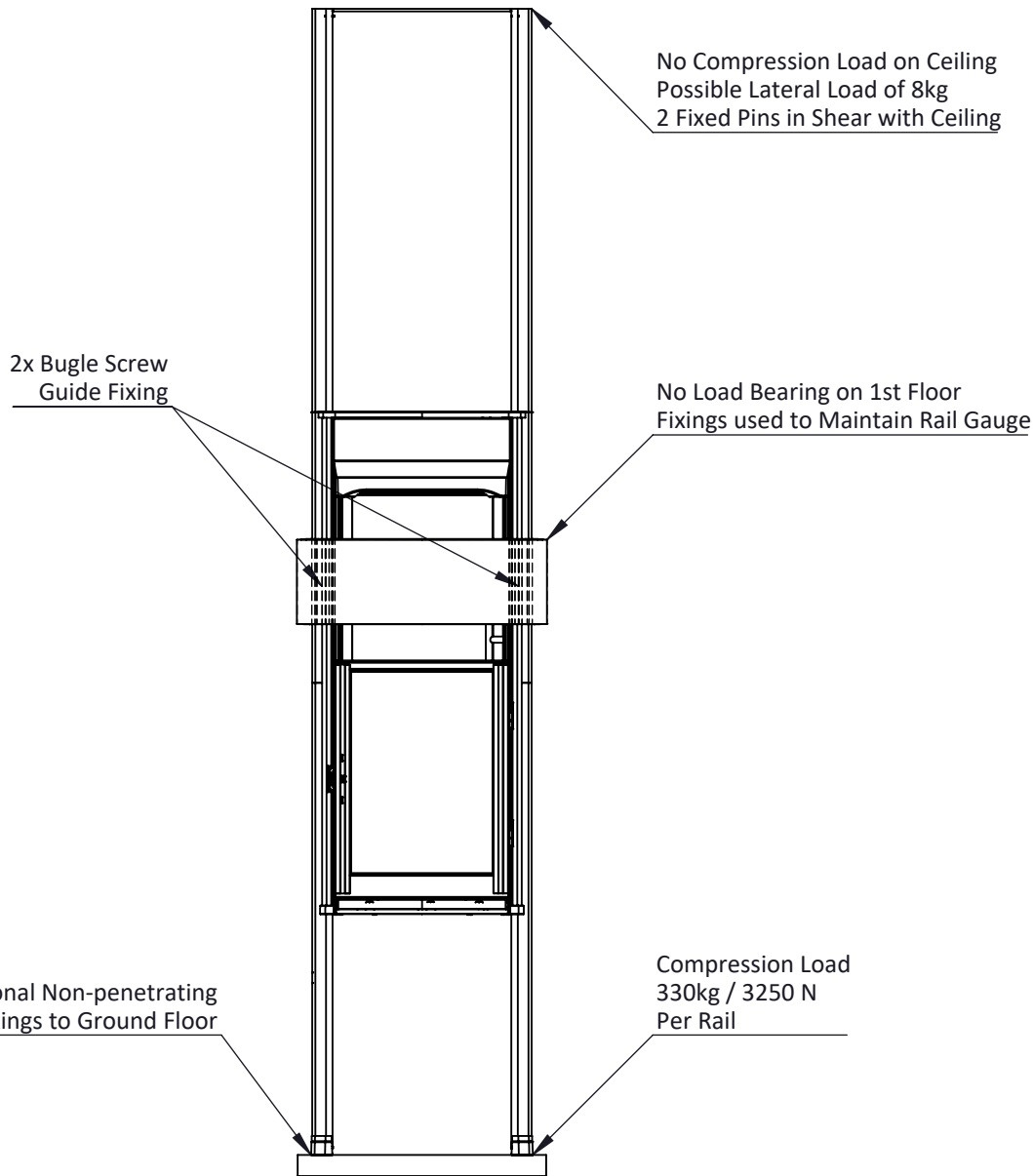







Rev	Description	Rev Date	Rev By



Technical Information:

Stiltz Trio + / Stiltz Trio + Thru Car

-  **DRIVE SYSTEM:**
Rope Drum, Braked Gear Motor Drive
-  **CAPACITY:**
MAX Capacity 250kg / 2-3 Persons
-  **TRAVEL:**
Standard: Up to 4500mm
Option: Up to 6000mm
-  **NO of FLOORS:**
Standard: 2 Maximum
with intermediate landing option
6.0 metre: 3 maximum
-  **SUPPLY VOLTAGE:**
240v 1PH 50HZ
-  **RUNNING CURRENT:**
3.2 AMP
-  **STARTING CURRENT:**
4.0 AMP
-  **STANDARD COLOUR:**
Grey (RAL 7038)
(Other colours available)

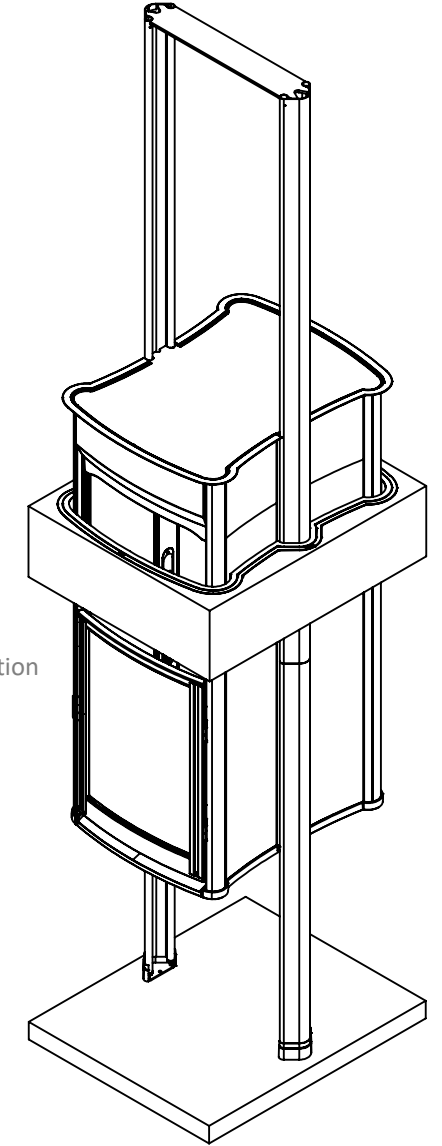

© Stiltz Ltd. 2017		TITLE Stiltz Trio+ Lift Installation	
Drawn JMG	Date 10/2017	A4	
 DIMENSIONS IN MM UNLESS OTHERWISE NOTED THIRD ANGLE PROJECTION - AS 1100		Dwg No -	Rev
		SCALE:	

Rev	Description	Rev Date	Rev By

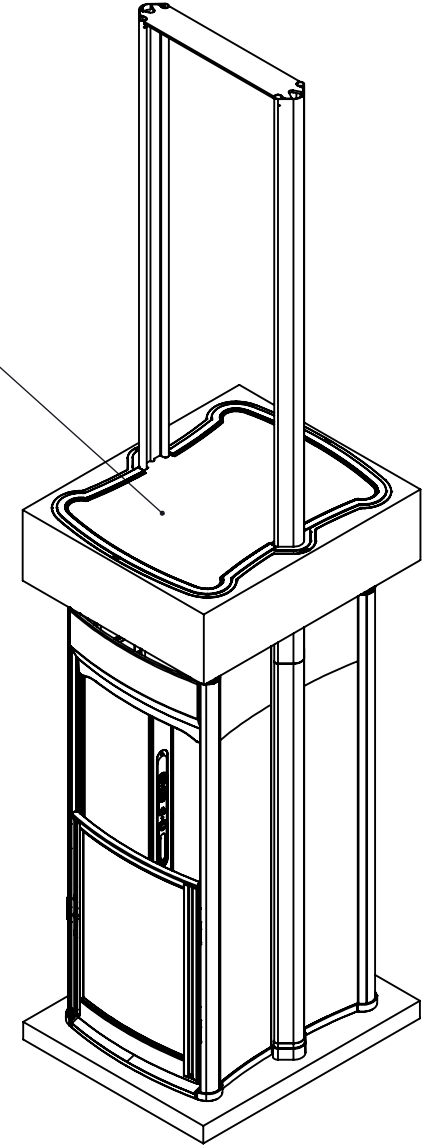
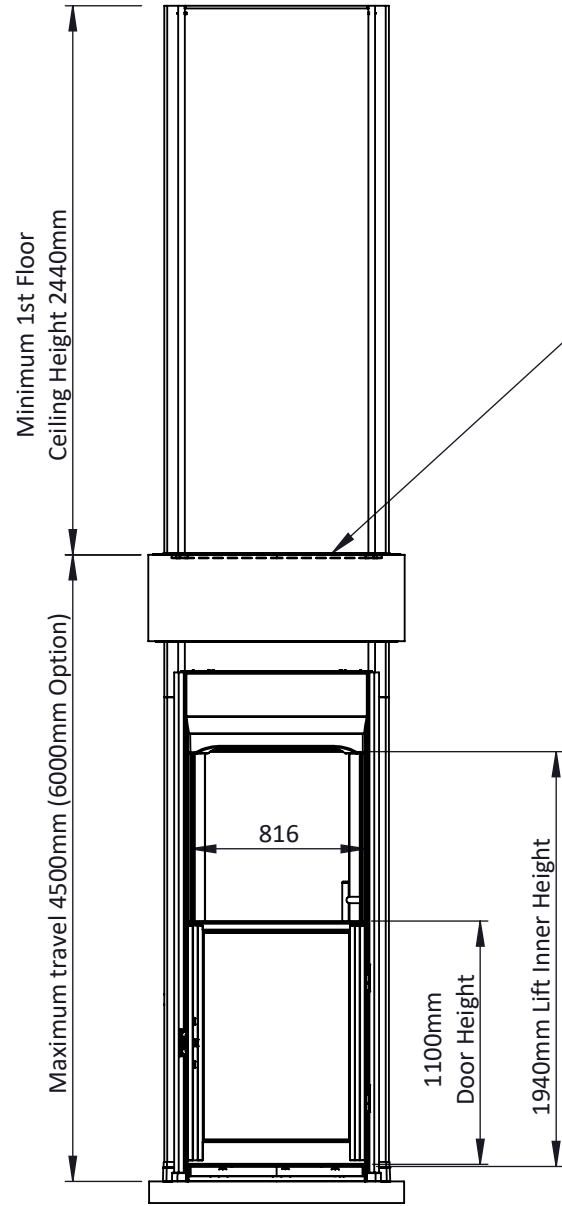
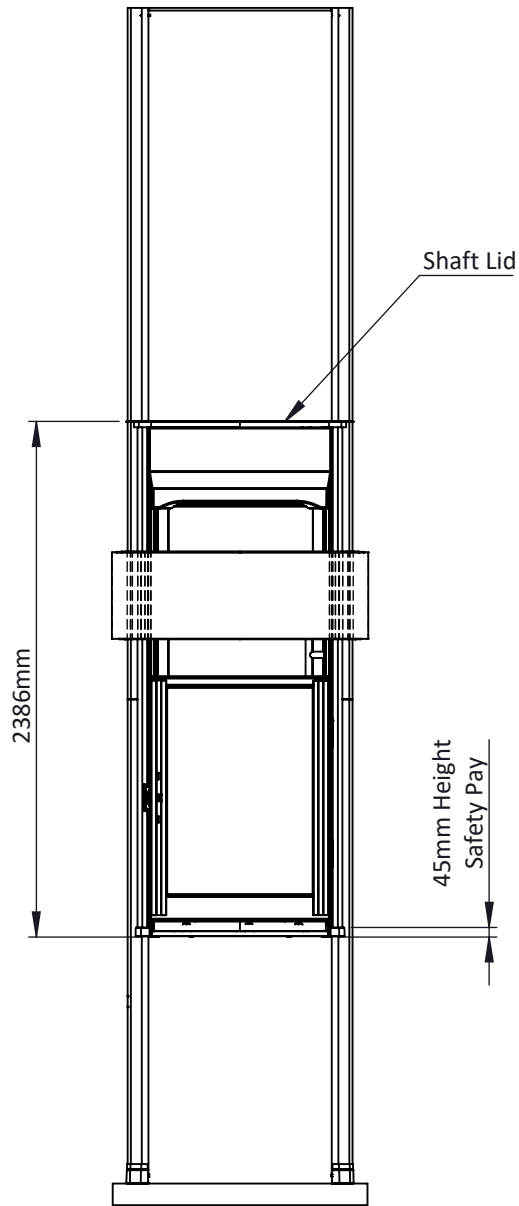

Standard Application

PRINT MAY BE REDUCED - DO NOT SCALE.

Rev	Description	Rev Date	Rev By

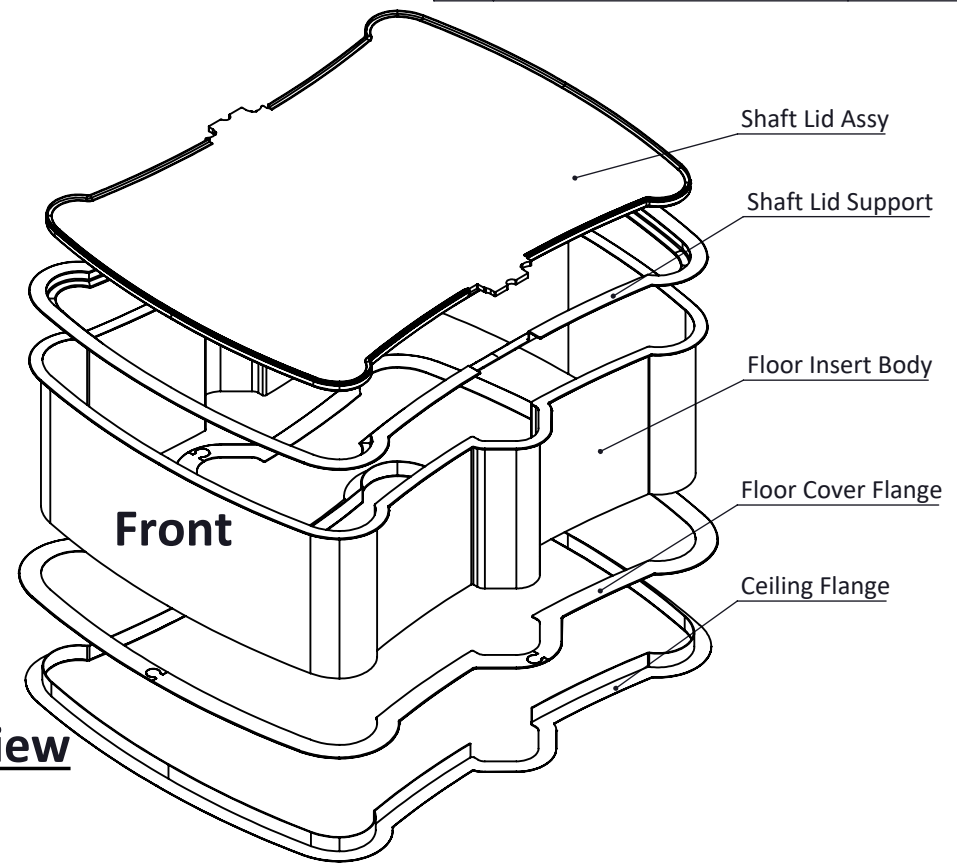
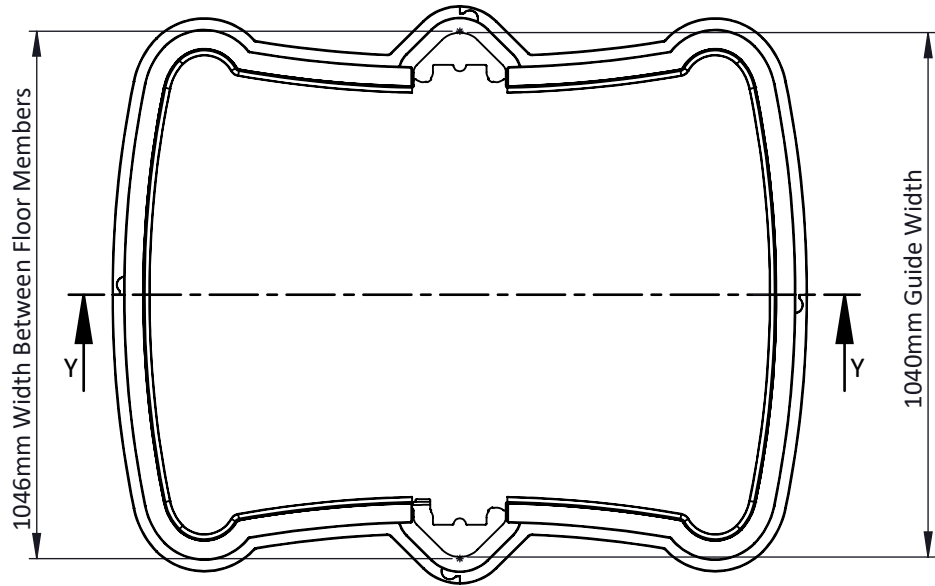

Explode View

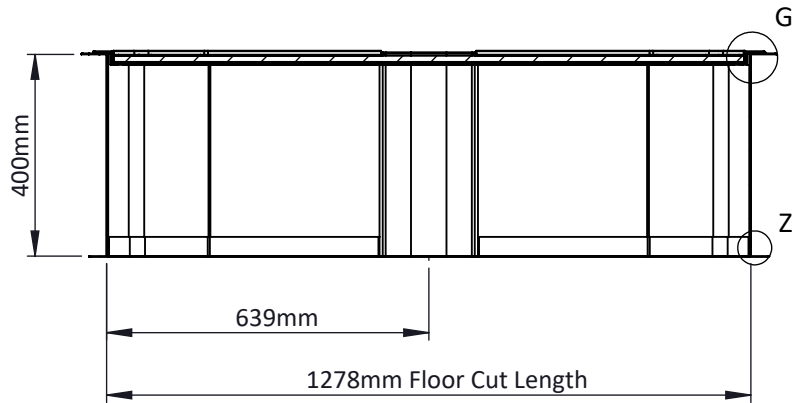

SECTION Y-Y

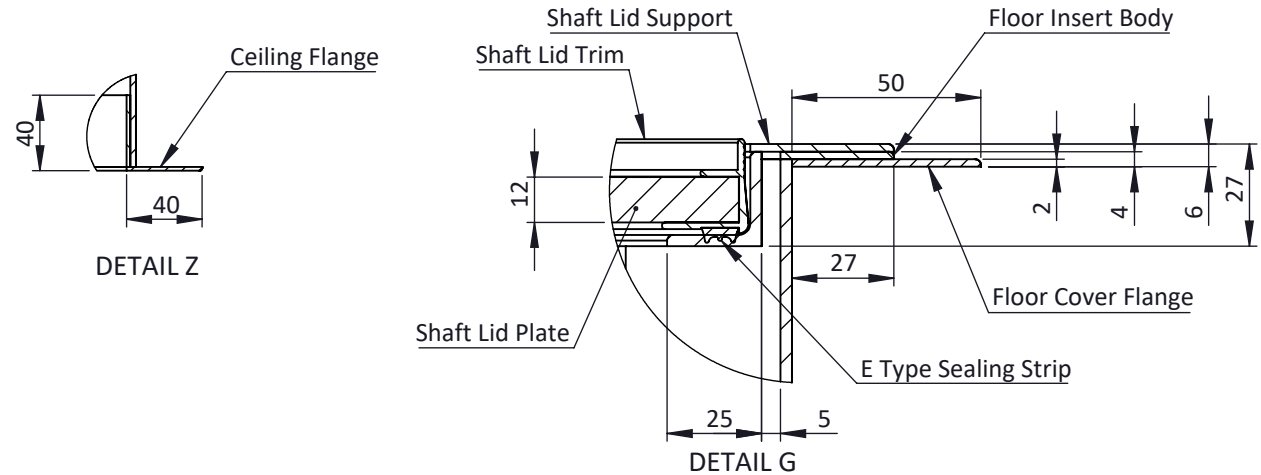

© Stiltz Ltd. 2017		TITLE Stiltz Trio+ Lift Floor Insert Body & Shaft Lid Assembly	
Drawn JMG	Date 10/2017	Dwg No -	
THIRD ANGLE PROJECTION - AS 1100		Rev	
DIMENSIONS IN MM UNLESS OTHERWISE NOTED		SCALE:	
A4			

Rev	Description	Rev Date	Rev By

**Template Tol.
+3 / -1**

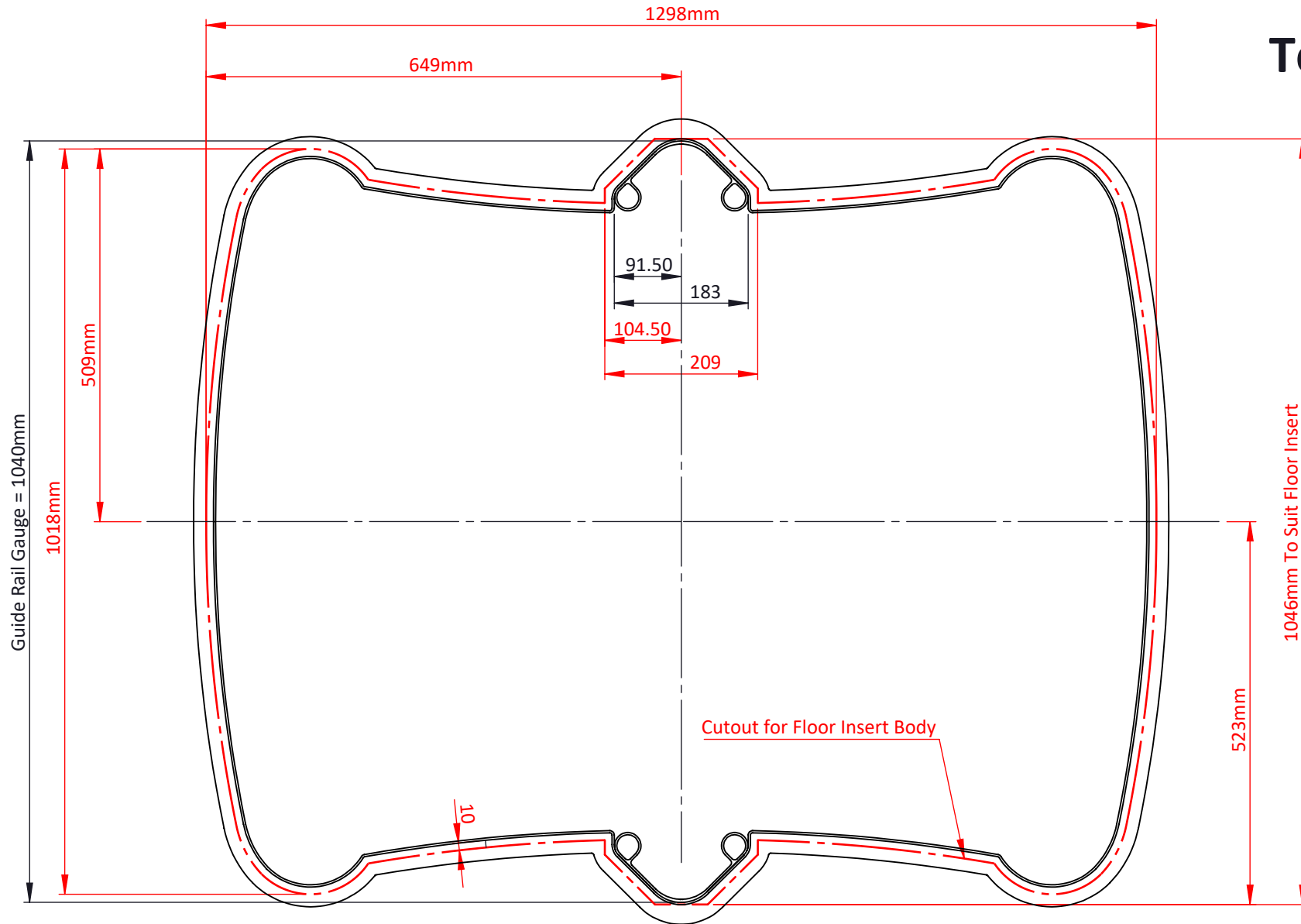

Rev	Description	Rev Date	Rev By

Doors can operate in RH and LH Positions

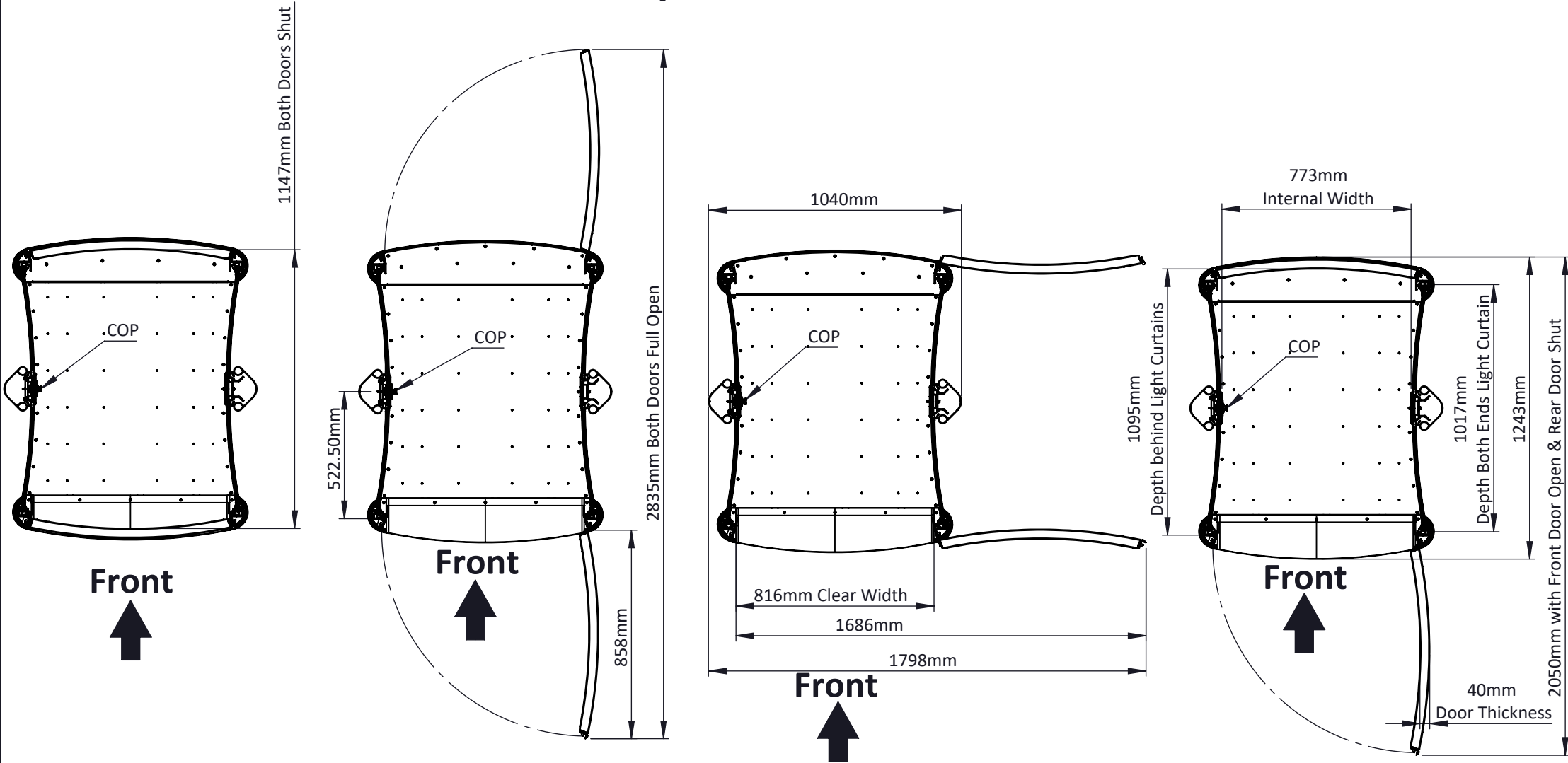

Rev	Description	Rev Date	Rev By

Bottom Door & Frame removed for Lift Installation

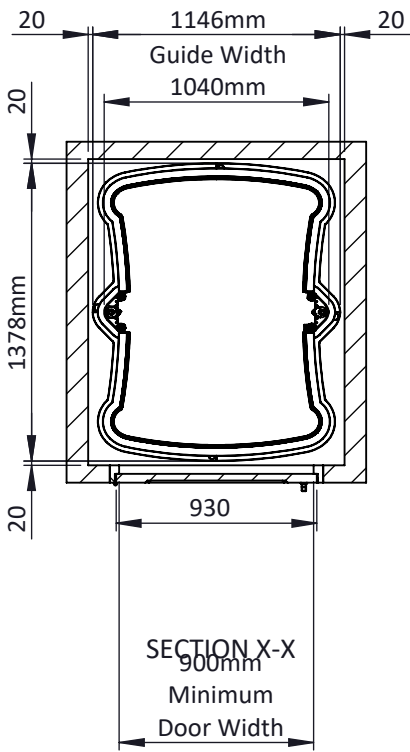

Wall Thickness By the Builder

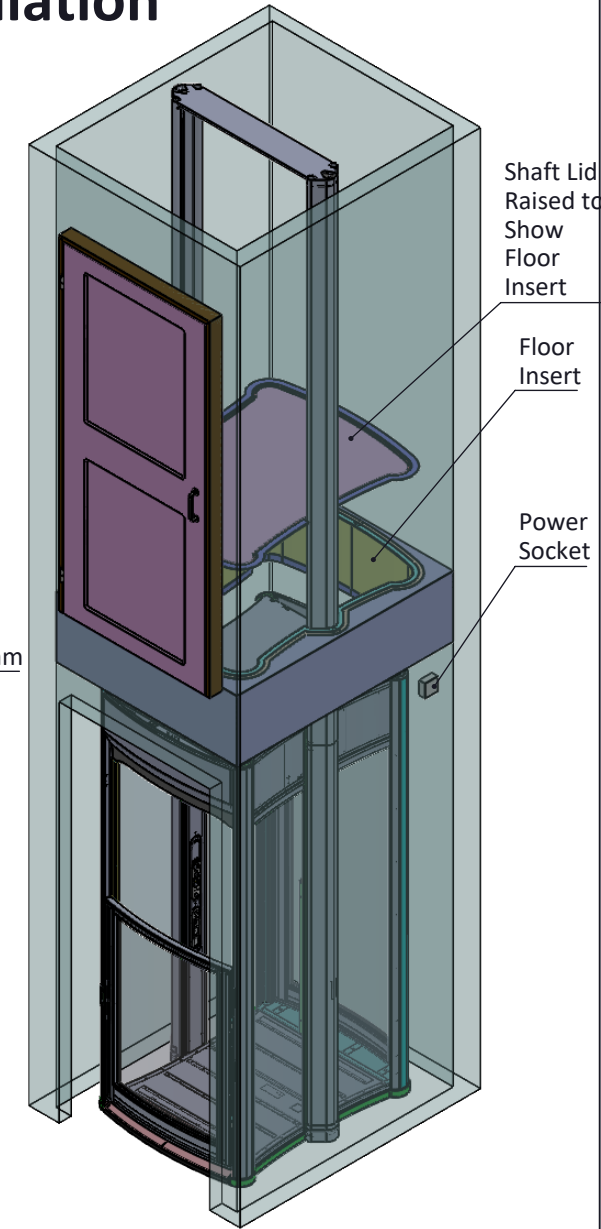
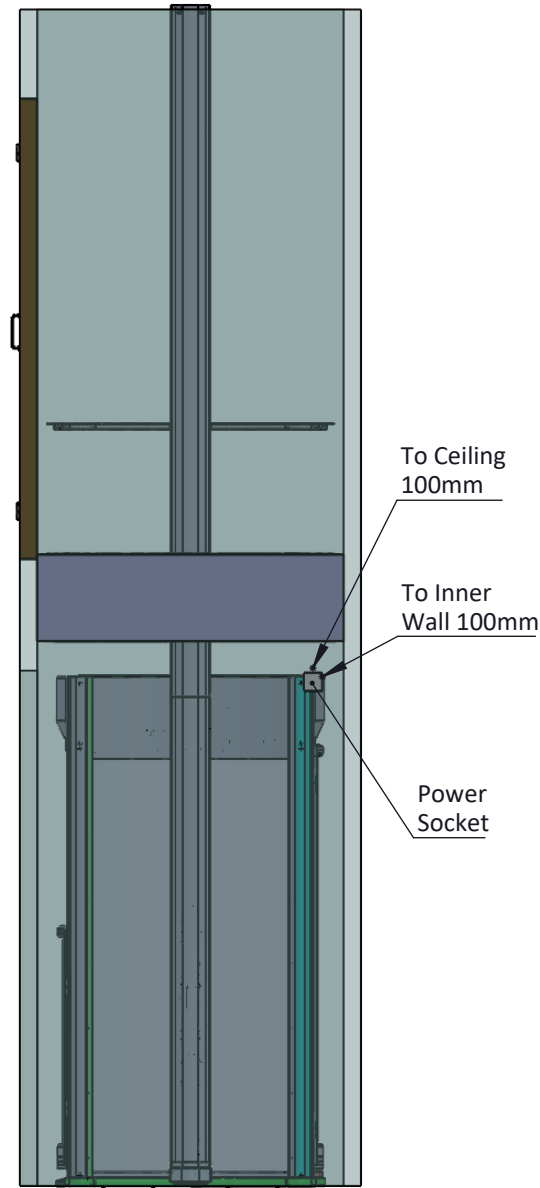
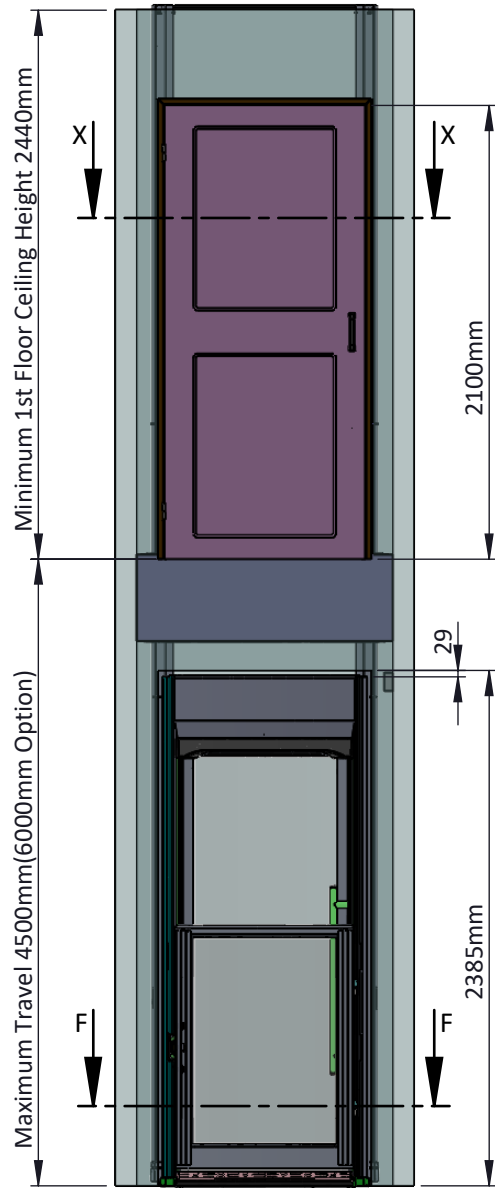
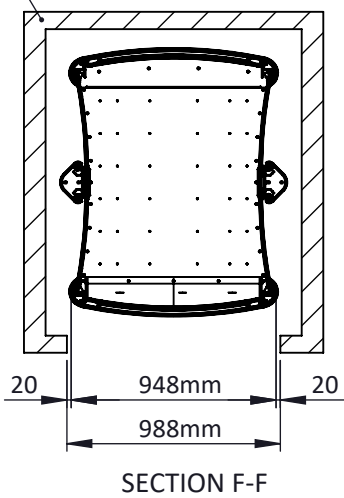

Shaft Application



© Stiltz Ltd. 2017	TITLE Stiltz Trio+ Shaft Information	
Drawn JMG	Date 10/2017	
THIRD ANGLE PROJECTION - AS 1100		A4
DIMENSIONS IN MM UNLESS OTHERWISE NOTED		Dwg No -
		Rev
		SCALE:

Rev	Description	Rev Date	Rev By

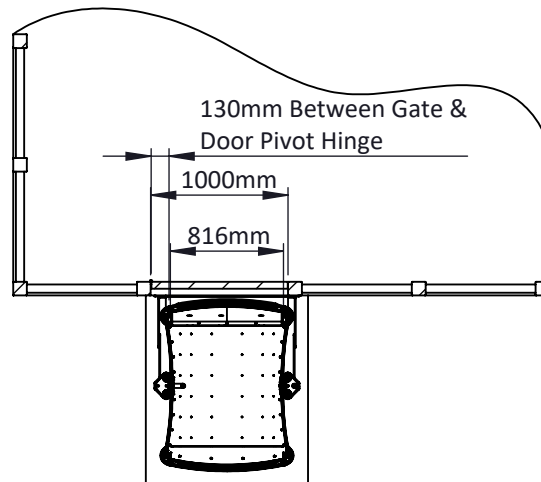
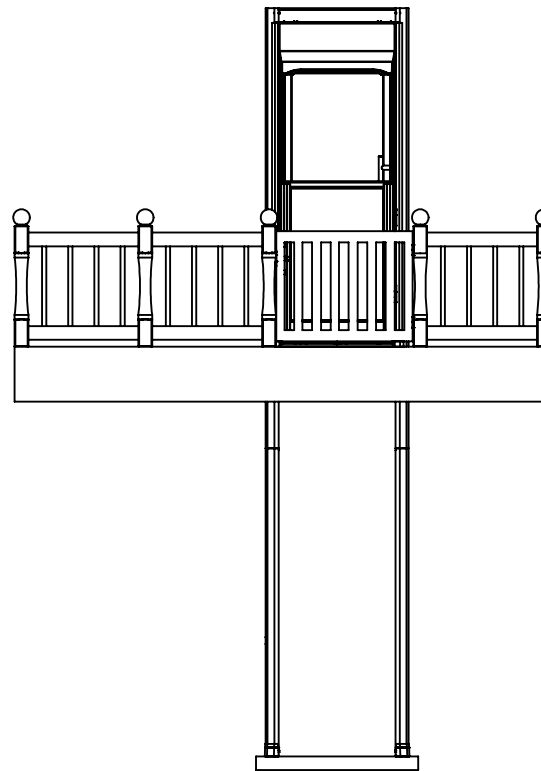
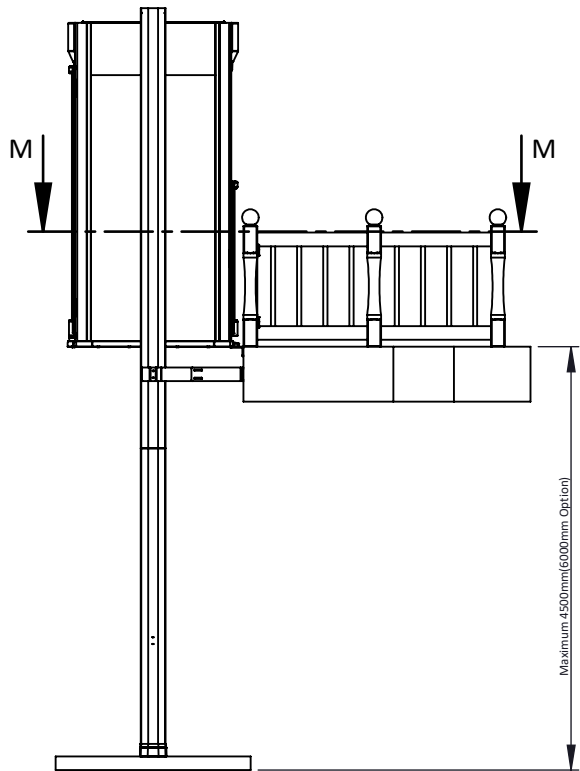

SECTION M-M

Door & Gate Close

© Stiltz Ltd. 2017	TITLE Stiltz Trio+ Lift Void Application	
Drawn JMG	Date 10/2017	
 THIRD ANGLE PROJECTION - AS 1100	DIMENSIONS IN MM UNLESS OTHERWISE NOTED	
	A4	Dwg No - SCALE:
		Rev

PRINT MAY BE REDUCED - DO NOT SCALE.

Rev	Description	Rev Date	Rev By

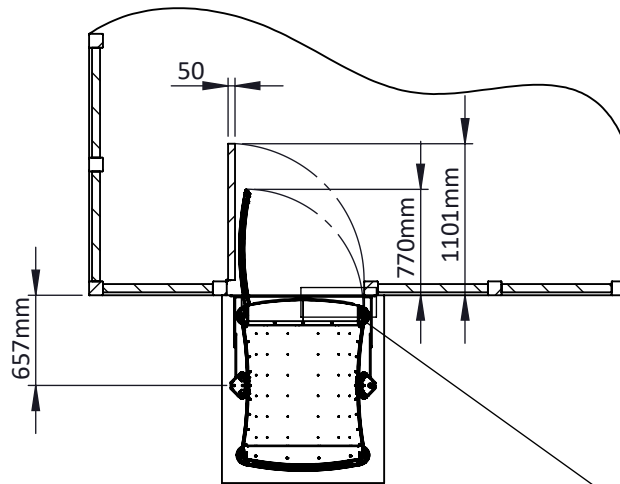
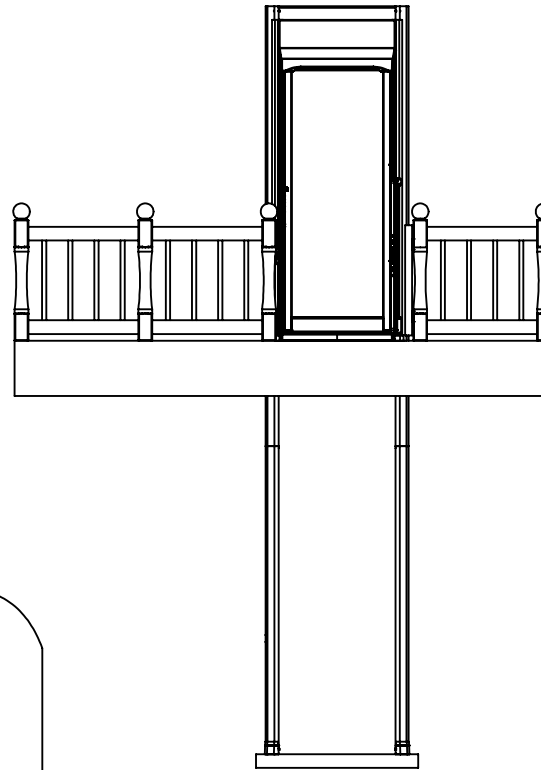
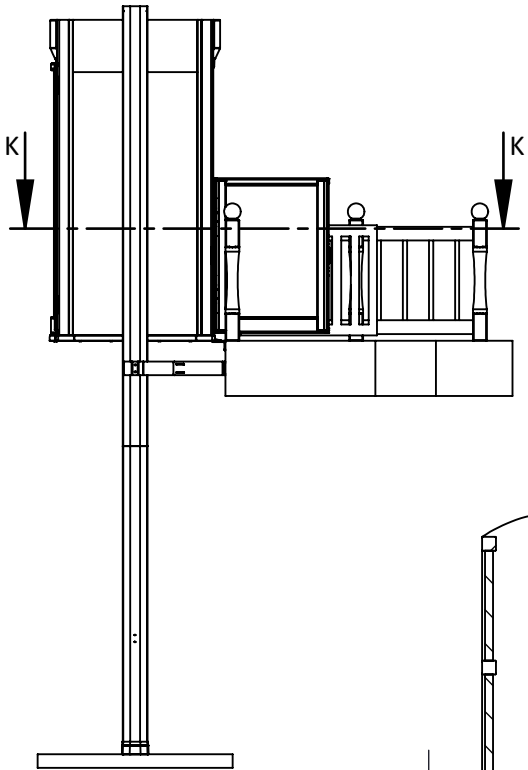

SECTION K-K

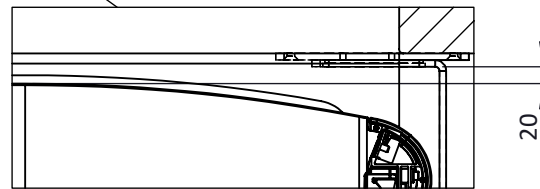

Door & Gate Open



©	Stiltz Ltd.	2017	TITLE	Stiltz Trio+ Lift Void Application
Drawn	JMG	Date	10/2017	
 DIMENSIONS IN MM UNLESS OTHERWISE NOTED THIRD ANGLE PROJECTION - AS 1100			A4	Dwg No -
			SCALE:	Rev